



STONECROP 32-03

2,111 SQ. FT.



Elevation A



Elevation B

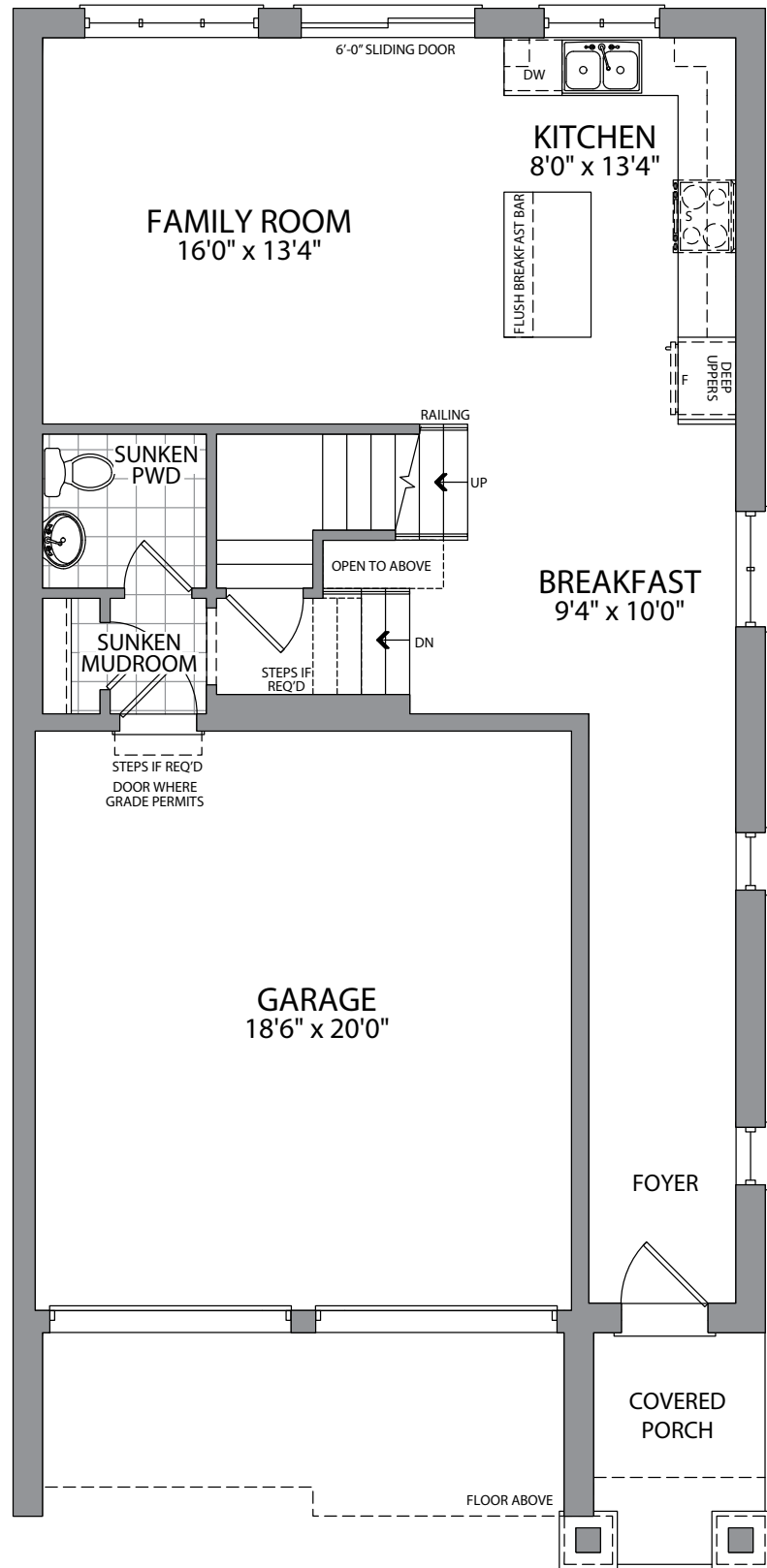

MAIN FLOOR ELEV. A

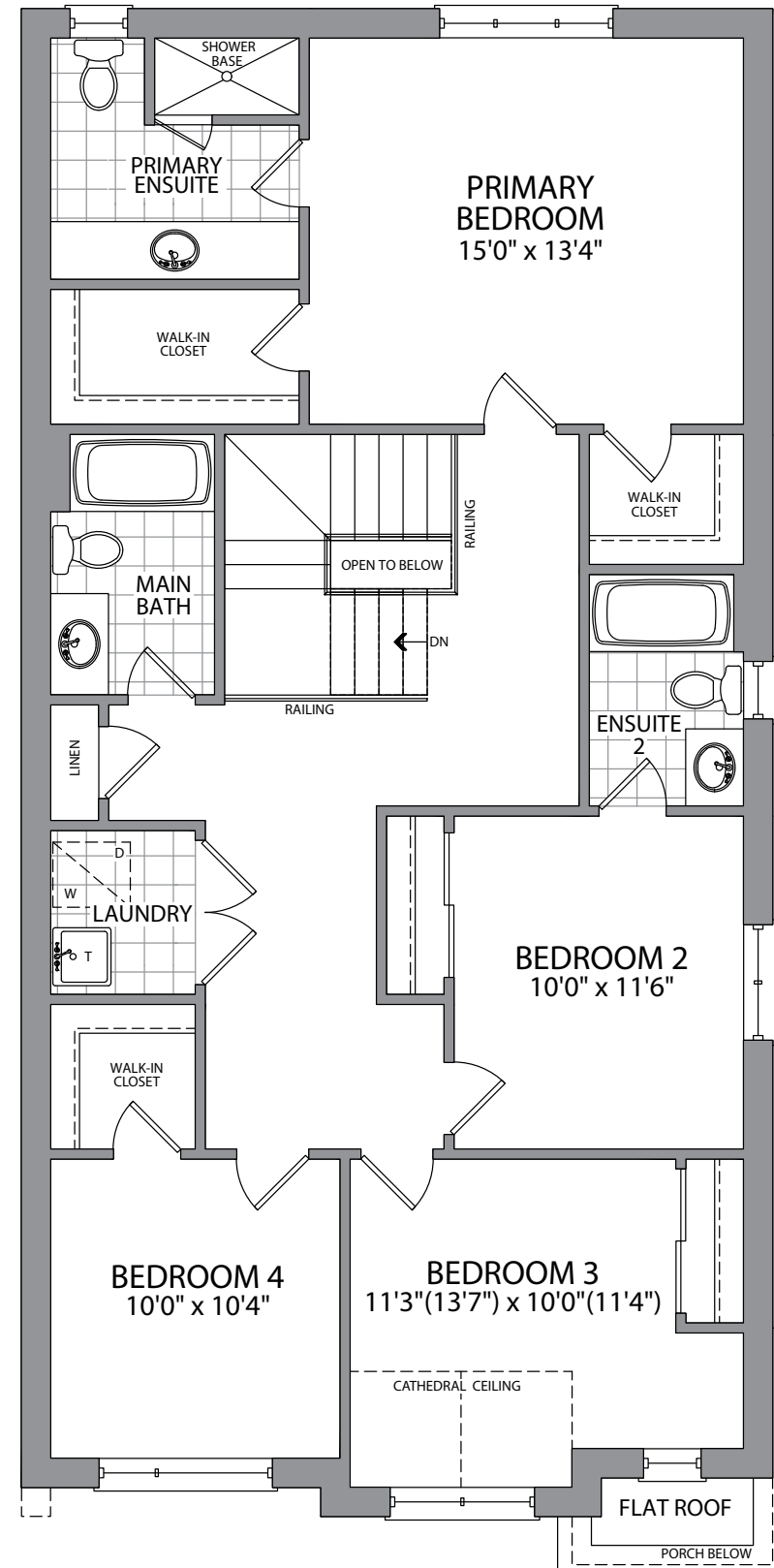

UPPER FLOOR ELEV. A

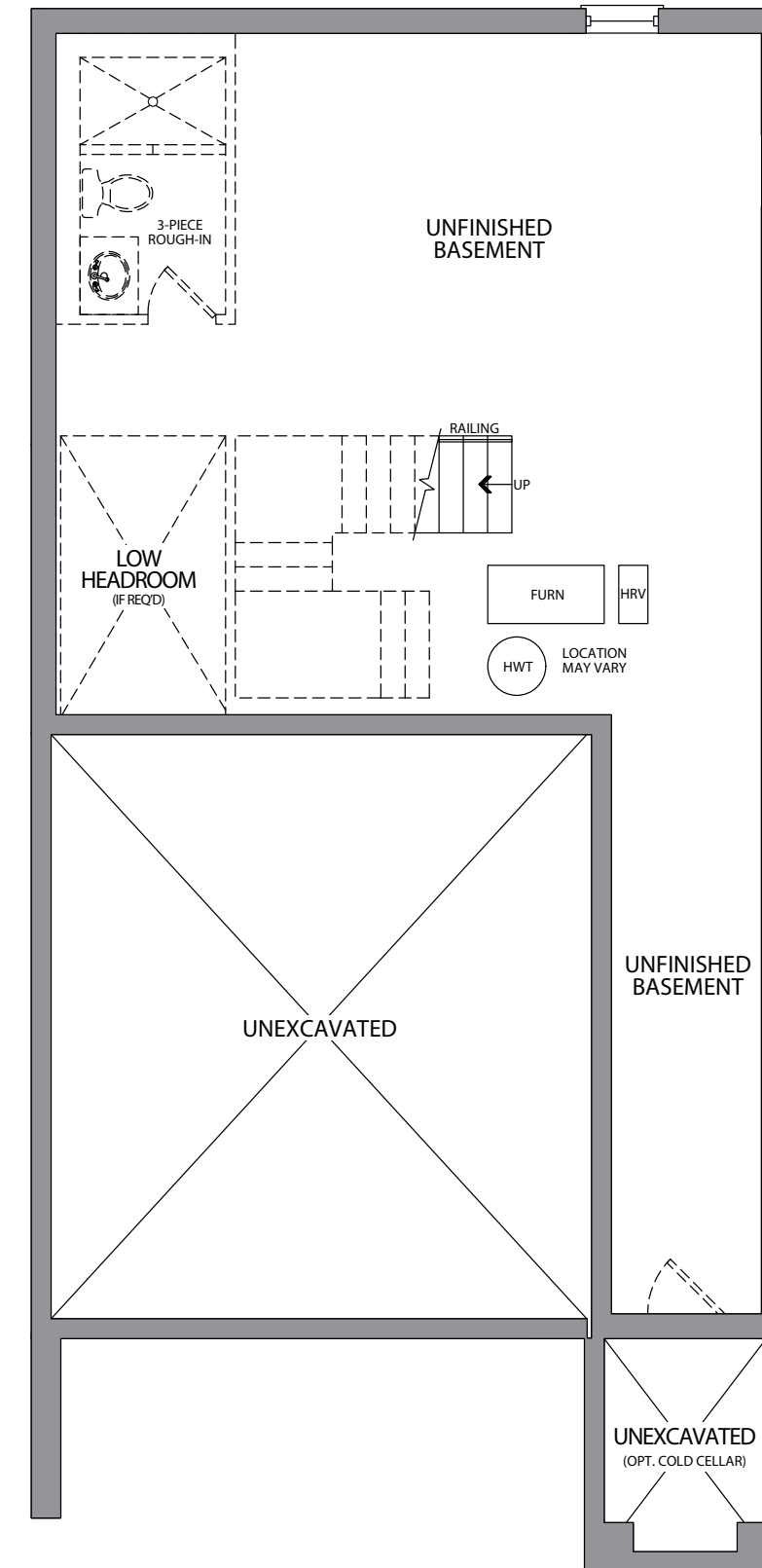

BASEMENT ELEV. A

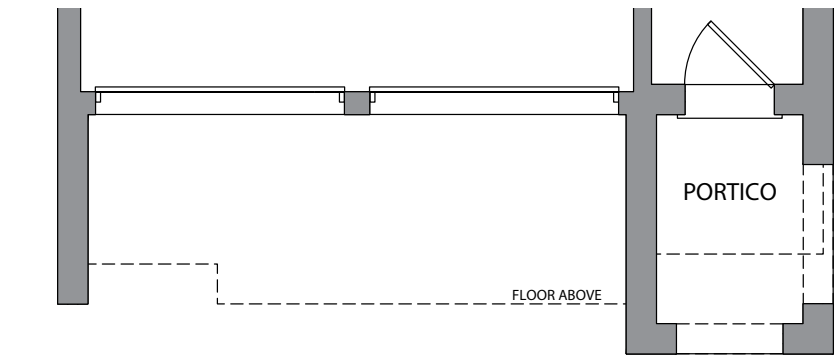

MAIN FLOOR ELEV. B

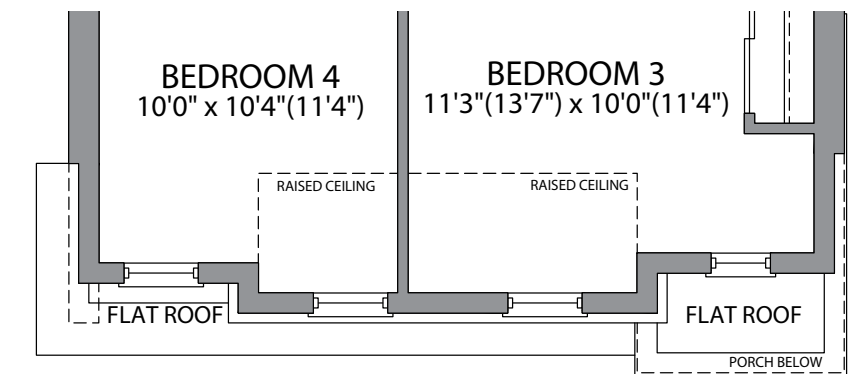

UPPER FLOOR ELEV. B

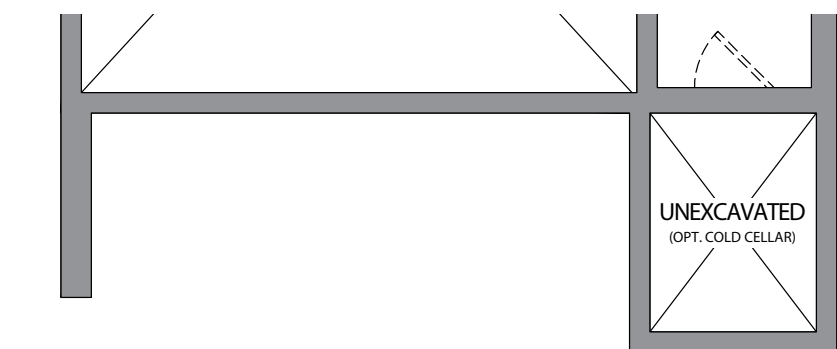

BASEMENT ELEV. B

All landscaping and images are artist's concept. Specifications, terms and conditions are subject to change without notice. All options shown are upgrades. The measurements adhere to the rules and regulations of the TARIION Warranty Corporation's official method for the calculation of the floor areas. Actual usable floor space may vary from the stated one. Renderings are Artist concept. E. & O. E. June 2026.

